

1 2 3 4 5 6 7 8

A

B

C

D

A

B

C

D

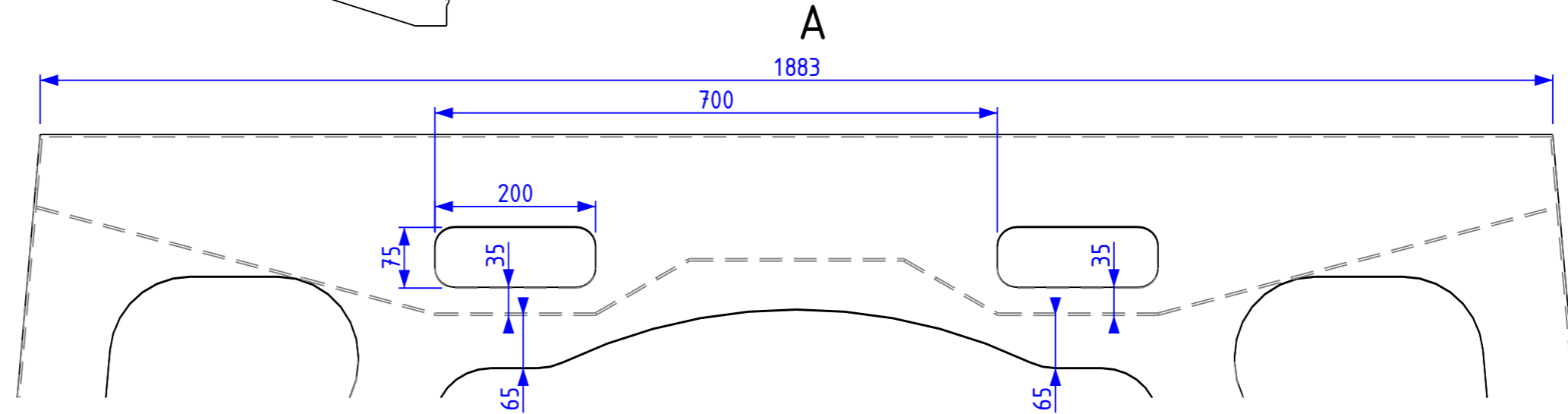
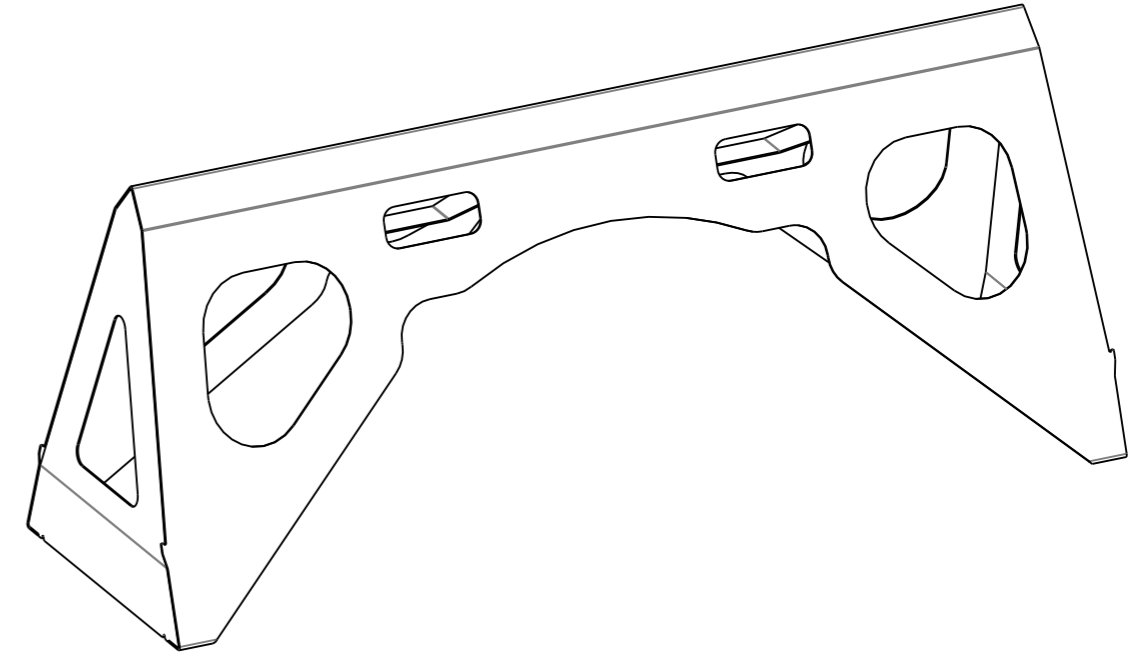
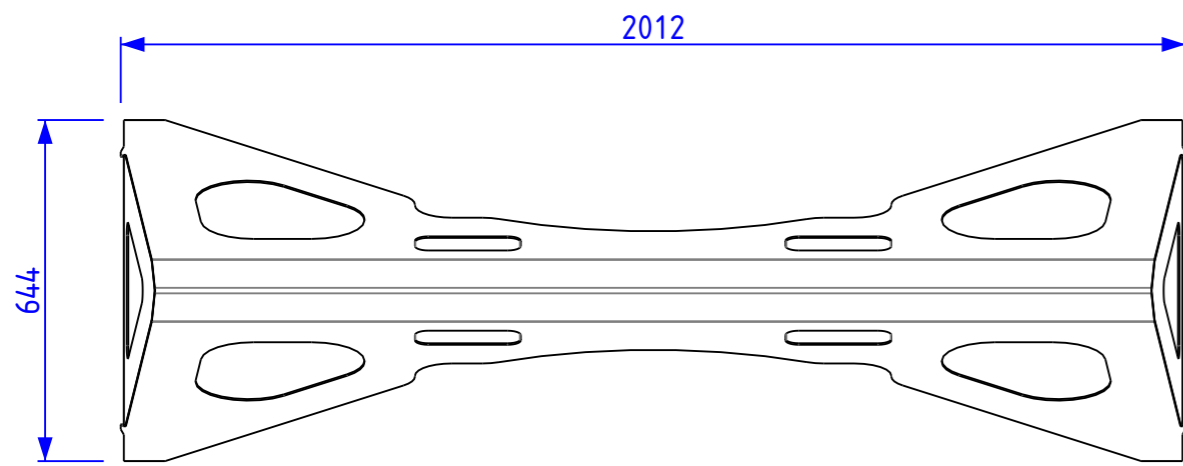
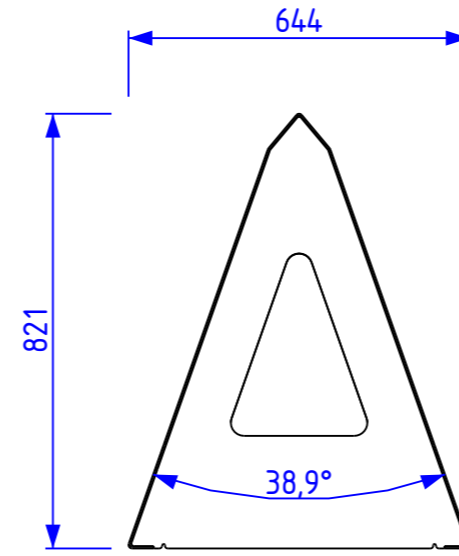
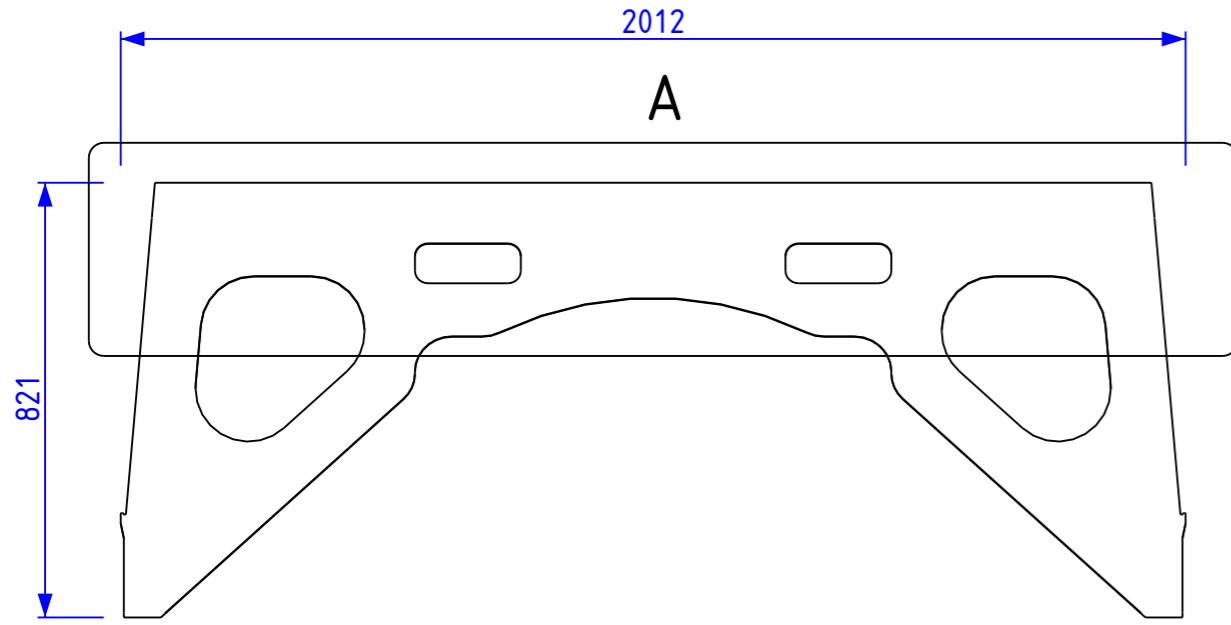

QTE	REP. PROD. Ass parents	Description assemblage(s)
1	-	Assemblage

Repère de production	QTE	DESIGNATION	MATIERE	Epaisseur	MASSE
4	2	Flanc long	Acier S355 EN 10025	3,00mm	5,47kg
6	1	Raidisseur long		3,00mm	7,12kg
8		Tole chassis long		3,00mm	37,03kg

Quantité: 1

Qté	Matière	Rev.	Masse U	Surface U
1	-	-	55,10kg	4,76m2
Designation: Long Rep. prod.: A2 Référence: - Affaire: - Numéro d'affaire: -			Zone: -	Revision: A 3
			Date révision: 14-04-24	Ech. 7:100
			Date création: 14-04-24	Format: A3
			Auteur: Admin	Folio: 1/1

BE-STretaux

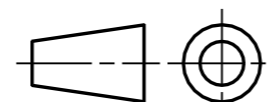

+32 474 369 305 Bstructe@outlook.com

1 2 3 4 5 6 7 8