

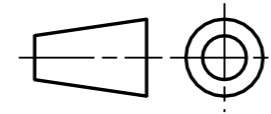

Repère de production	QTE	DESIGNATION	MATIERE	Epaisseur	MASSE
-	4	Ess-10269213	-	-	-
4	1	Flanc	Acier Corten	3,00mm	6,32kg
5				3,00mm	
6	Latte arrière	3,00mm		0,90kg	
1	2	Renfort		2,00mm	0,99kg
2				2,00mm	1,00kg
3	1	Toile principale		3,00mm	41,11kg

Quantité: -

Be-MeubleExt



Qté	-	Matière	-	Rev.	-	Masse U	57,64kg	Surface U	5,10m2
		Designation	Caisse longue			Zone	-		
+32 474 369 305		Rep. prod.	-	Référence	-	Date révision	26-04-24	Revision	A 5
Bstructe@outlook.com		Affaire	-			Date création	26-04-24	Ech.	2 : 25
		Numéro d'affaire	-			Auteur	Admin	Format	A3
						Folio	1/2		-

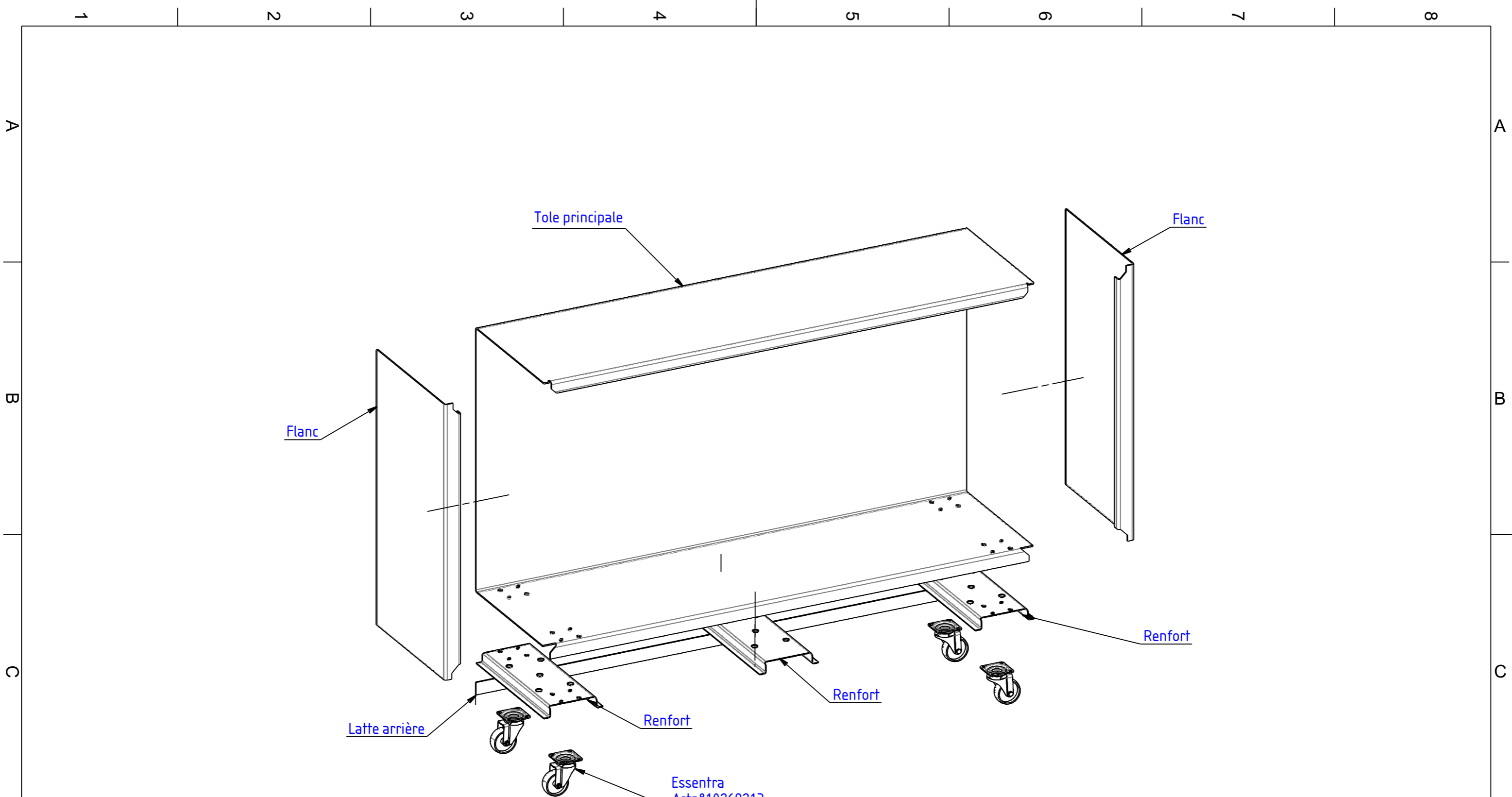

Repère de production	REP.	QTE	DESIGNATION	MATERIAU	EPAISSEUR	MASSE
-	1	2	Renfort	Acier Corten	2mm	1,98kg
-	2		Renfort		2mm	1,00kg
-	3	1	Flanc		3mm	6,32kg
-	4		Flanc		3mm	
-	5		Latte arrière		3mm	0,90kg
-	6		Toile principale		3mm	41,11kg

Quantité: -

Be-MeubleExt

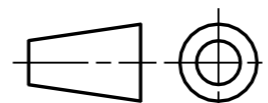

Qté	-	Matière	-	Rev.	-	Masse U	57,64kg	Surface U	5,10m2
		Designation		Caisse longue		Zone		-	
+32 474 369 305		Rep. prod.		-		Date révision		26-04-24	
Bstructe@outlook.com		Affaire		-		Date création		26-04-24	
		Numéro d'affaire		-		Ech.		2 : 25	
						Auteur		Admin	
						Format		A3	
						Folio		2/2	