

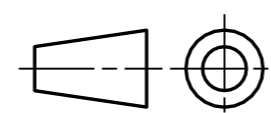

Repère de production	QTE	DESIGNATION	MATIERE	Epaisseur	MASSE
-	4	Ess-10269213	-	-	-
4	1	Flanc	Acier Corten	3,00mm	6,32kg
5				3,00mm	
6		Latte arrière		3,00mm	0,32kg
1	2	Renfort		2,00mm	0,99kg
3	1	Toile principale		3,00mm	14,60kg

Quantité: -

Be-MeubleExt



Qté	-	Matière	-	Rev.	-	Masse U	29,55kg	Surface U	2,65m2
		Designation		Caisse courte		Zone	-		
+32 474 369 305		Rep. prod.		Référence		Date révision	26-04-24	Revision A 2	
Bstructe@outlook.com		Affaire				Date création	26-04-24	Ech. 2 : 25 Format A3	
		Numéro d'affaire				Auteur	Admin	Folio 1/2 -	

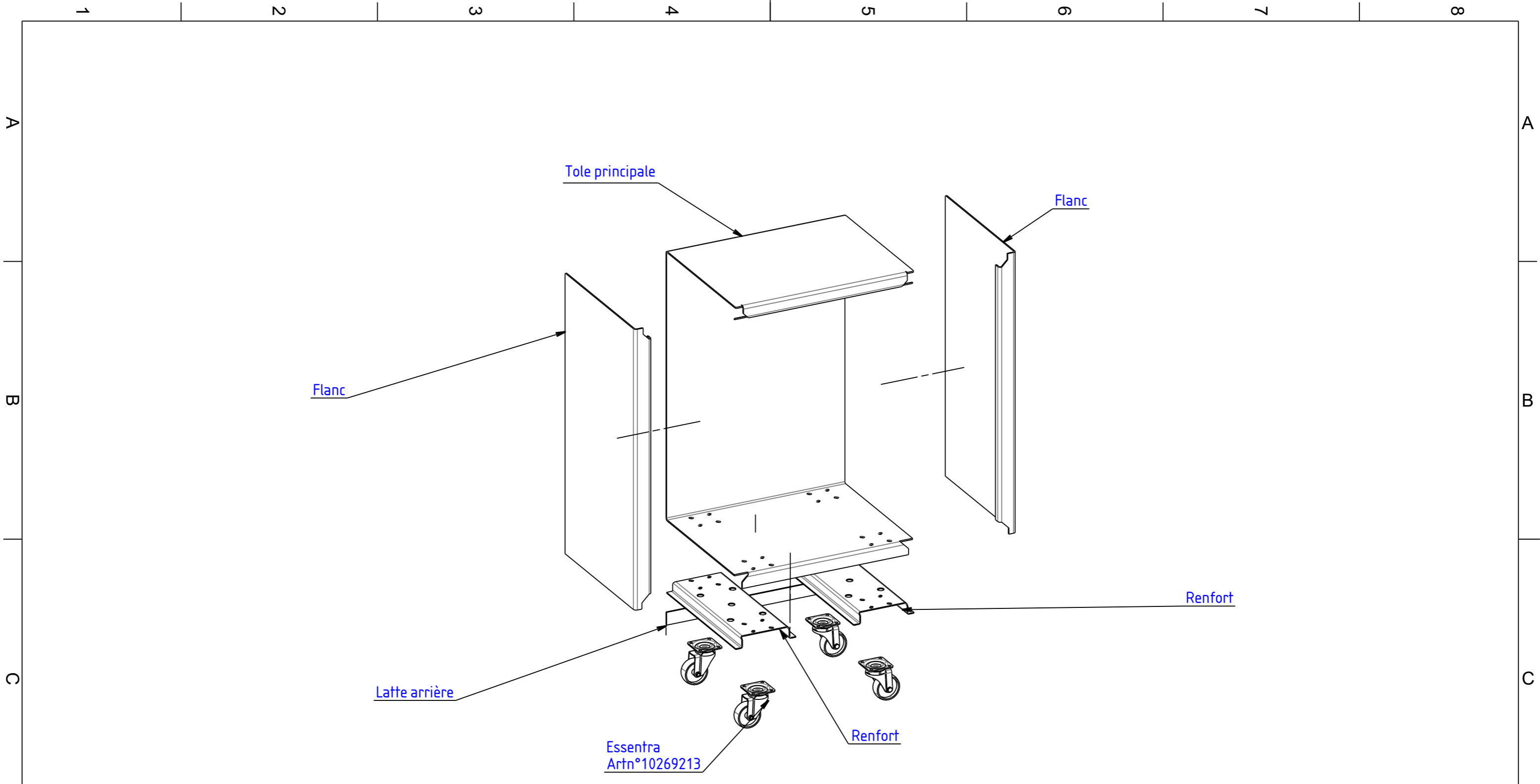

Repère de production	REP.	QTE	DESIGNATION	MATERIAU	EPAISSEUR	MASSE
-	1	2	Renfort	Acier Corten	2mm	1,98kg
-	3	1	Flanc		3mm	6,32kg
-	4		Flanc		3mm	0,32kg
-	5		Latte arrière		3mm	14,60kg
-	6		Toile principale		3mm	

Quantité: -

Be-MeubleExt

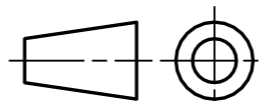

Qté	-	Matière	-	Rev.	-	Masse U	29,55kg	Surface U	2,65m2
		Designation		Caisse courte		Zone		-	
+32 474 369 305		Rep. prod.		-		Date révision		26-04-24	
Bstructe@outlook.com		Affaire		-		Date création		26-04-24	
		Numéro d'affaire		-		Auteur		Admin	
						Revision		A 2	
						Ech.		2 : 25	
						Format		A3	
						Folio		2/2	