

1 2 3 4 5 6 7 8

A

B

C

D

QTE	REP. PROD. Ass parents	Description assemblage(s)
-----	------------------------	---------------------------

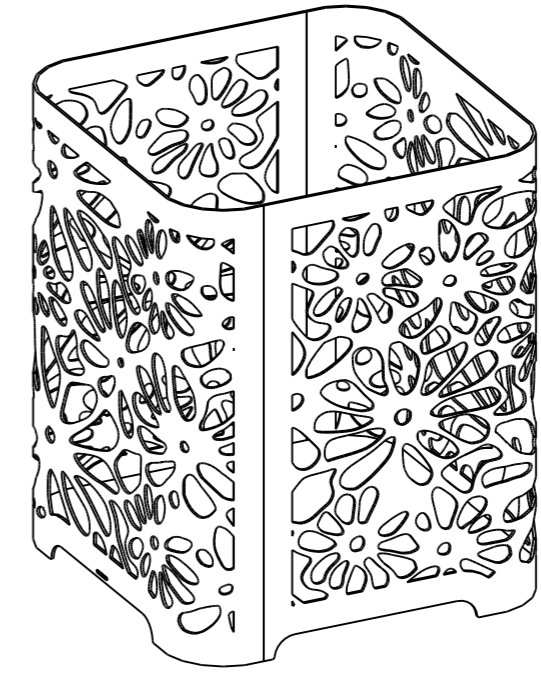
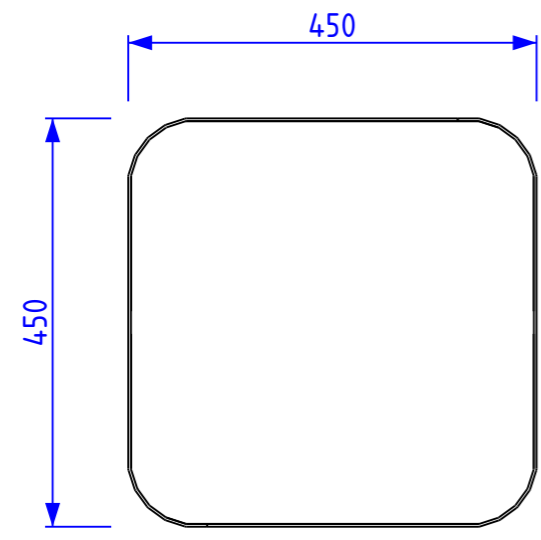
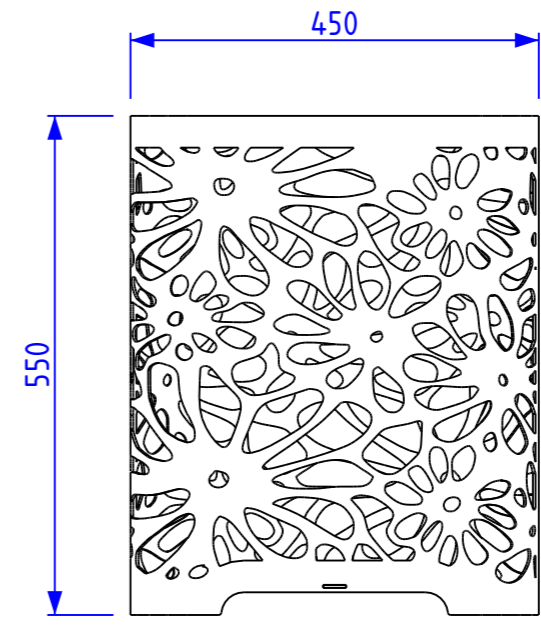
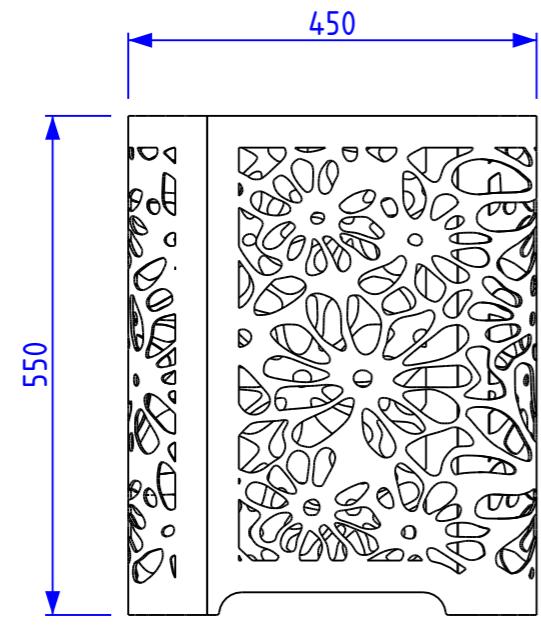

Repère de production	QTE	DESIGNATION	MATIERE	Epaisseur	MASSE
1	2	Pièce	Acier	3,00mm	6,46kg
2	1			3,00mm	4,54kg

Quantité: 1

BE-SBrasero

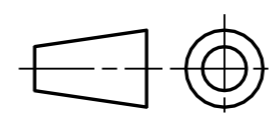

Qté	1	Matière	-	Rev.	-	Masse U	17,45kg	Surface U	1,64m2
		Designation	Brasero Car-rond			Zone	-	Revision	
		Rep. prod.	-	Référence	-	Date révision	16-04-24	A 1	
+32 474 369 305 Bstructe@outlook.com		Affaire	-			Date création	16-04-24	Ech.	3 : 25
		Numéro d'affaire	-			Auteur	Admin	Folio	1/1
							Format		A3

1 2 3 4 5 6 7 8

A

B

C

D