

QTE	Assemblage(s) Parent(s)	Description assemblage(s)
-----	-------------------------	---------------------------

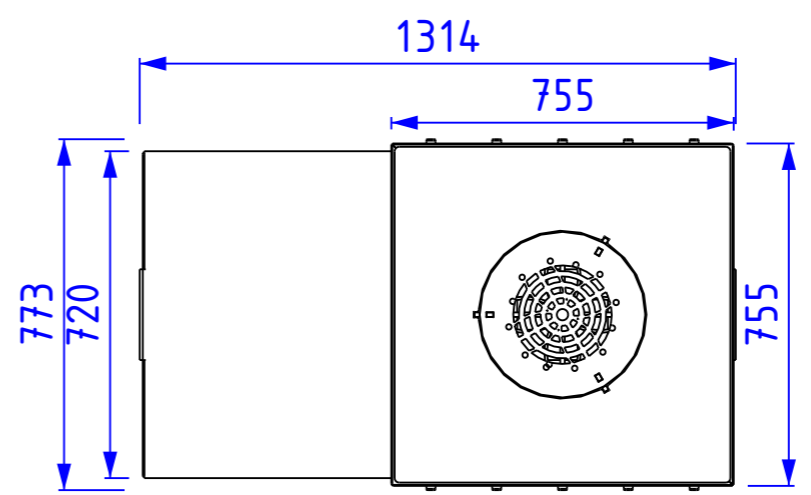
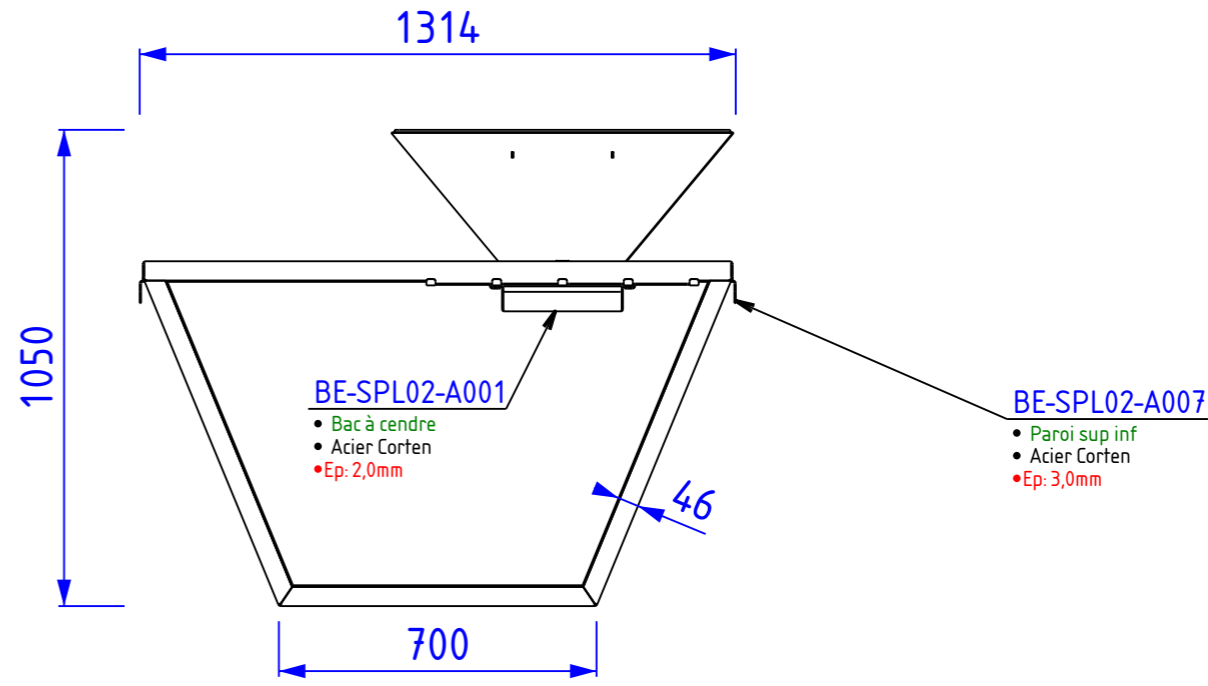
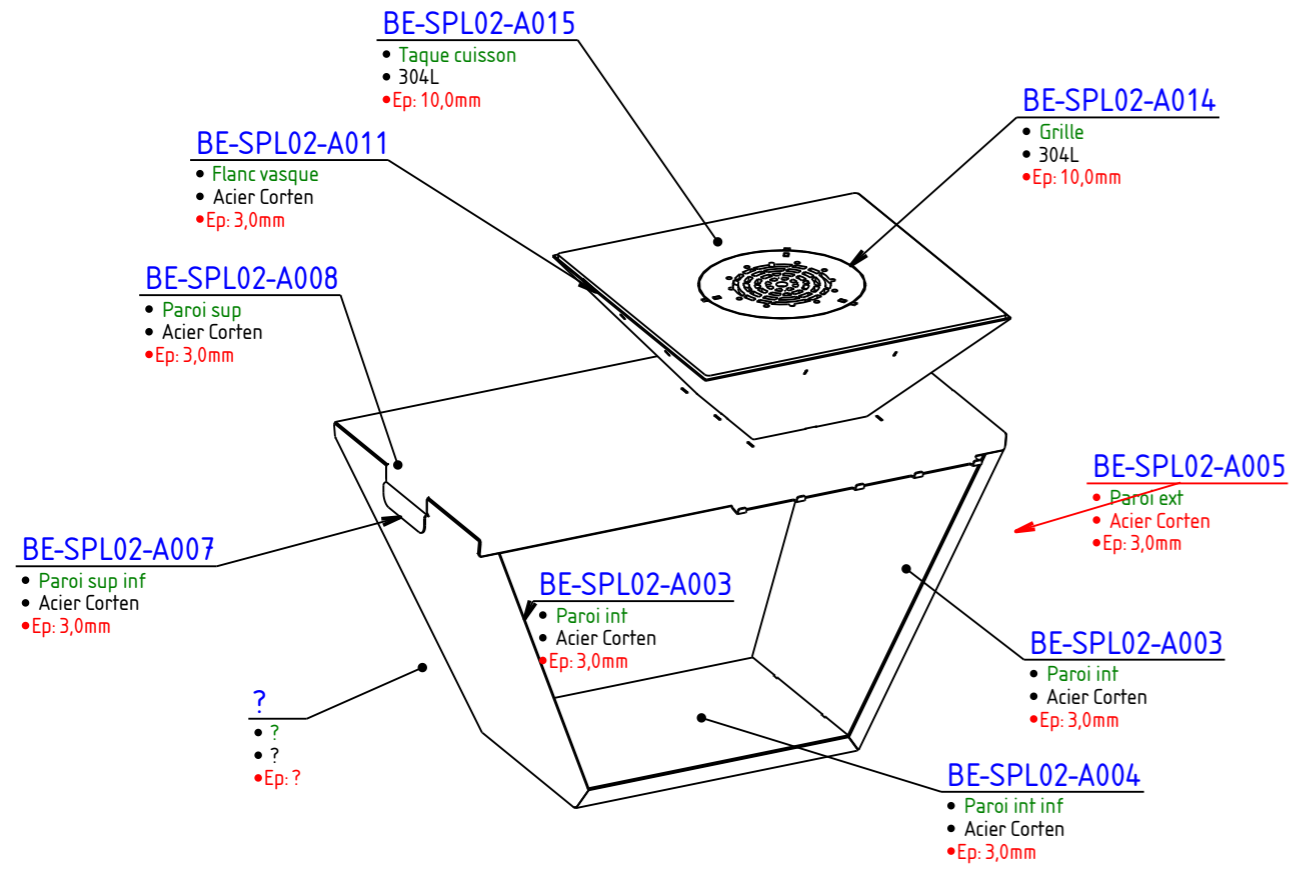

QTE	Référence	DESIGNATION	MATIERE	Epaisseur	MASSE
1	BE-SPL02-A001	Bac à cendre	Acier Corten	2,00mm	3,49kg
	BE-SPL02-A002	Grille de fond		3,00mm	1,17kg
	BE-SPL02-A01	Grille sup	-	-	7,61kg
	BE-SPL02-A014	Grille	304L	10,00mm	6,83kg
3	BE-SPL02-A013	Pied grille	304L	10,00mm	0,26kg
1	BE-SPL02-A04	Meuble	-	-	106,85kg
	BE-SPL02-A005	Paroi ext	Acier Corten	3,00mm	33,62kg
2	BE-SPL02-A003	Paroi int		3,00mm	10,48kg
1	BE-SPL02-A004	Paroi int inf		3,00mm	8,00kg
	BE-SPL02-A008	Paroi sup		3,00mm	23,36kg
	BE-SPL02-A007	Paroi sup inf	3,00mm	19,03kg	
2	BE-SPL02-A006	Support bac	-	3,00mm	0,94kg
1	BE-SPL02-A03	Plaque cuisson	-	-	34,78kg
3	BE-SPL02-A012	Support grille	304L	3,00mm	0,02kg
	BE-SPL02-A015	Taquet cuisson		10,00mm	34,73kg
1	BE-SPL02-A02	Vasque	-	-	19,55kg
2	BE-SPL02-A011	Flanc vasque	Acier Corten	3,00mm	9,52kg
	BE-SPL02-A009	Support taquet		3,00mm	0,06kg
4	BE-SPL02-A010	Support taquet sym	-	3,00mm	

Quantité: 1

Qté	1	Matière	-	Rev.	-	Masse U	173,45kg	Surface U	12,68m ²
		Designation	Plancha		Zone	-			
		Rep. prod.	-	Référence	BE-SPL02-A00	Date révision	01-04-24	Revision	A 3
		Affaire	-	Date création	22-07-23	Ech.	3 : 50	Format	A3
		Numéro d'affaire	-	Auteur	Admin	Folio	1/1		-

BE-SPL