

QTE	REP. PROD. Ass parents	Description assemblage(s)
-----	------------------------	---------------------------

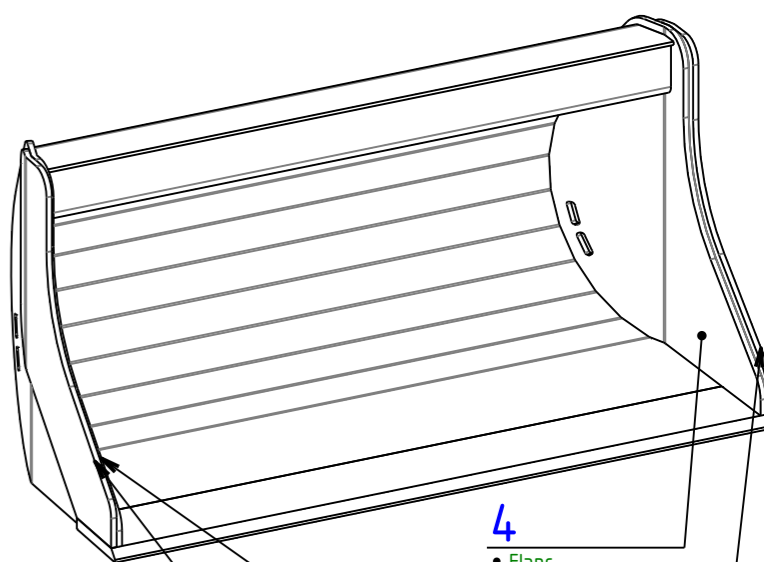
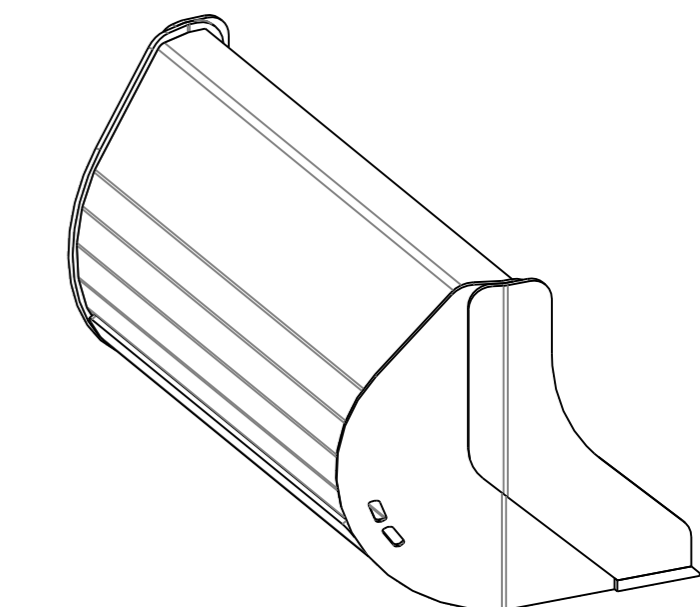
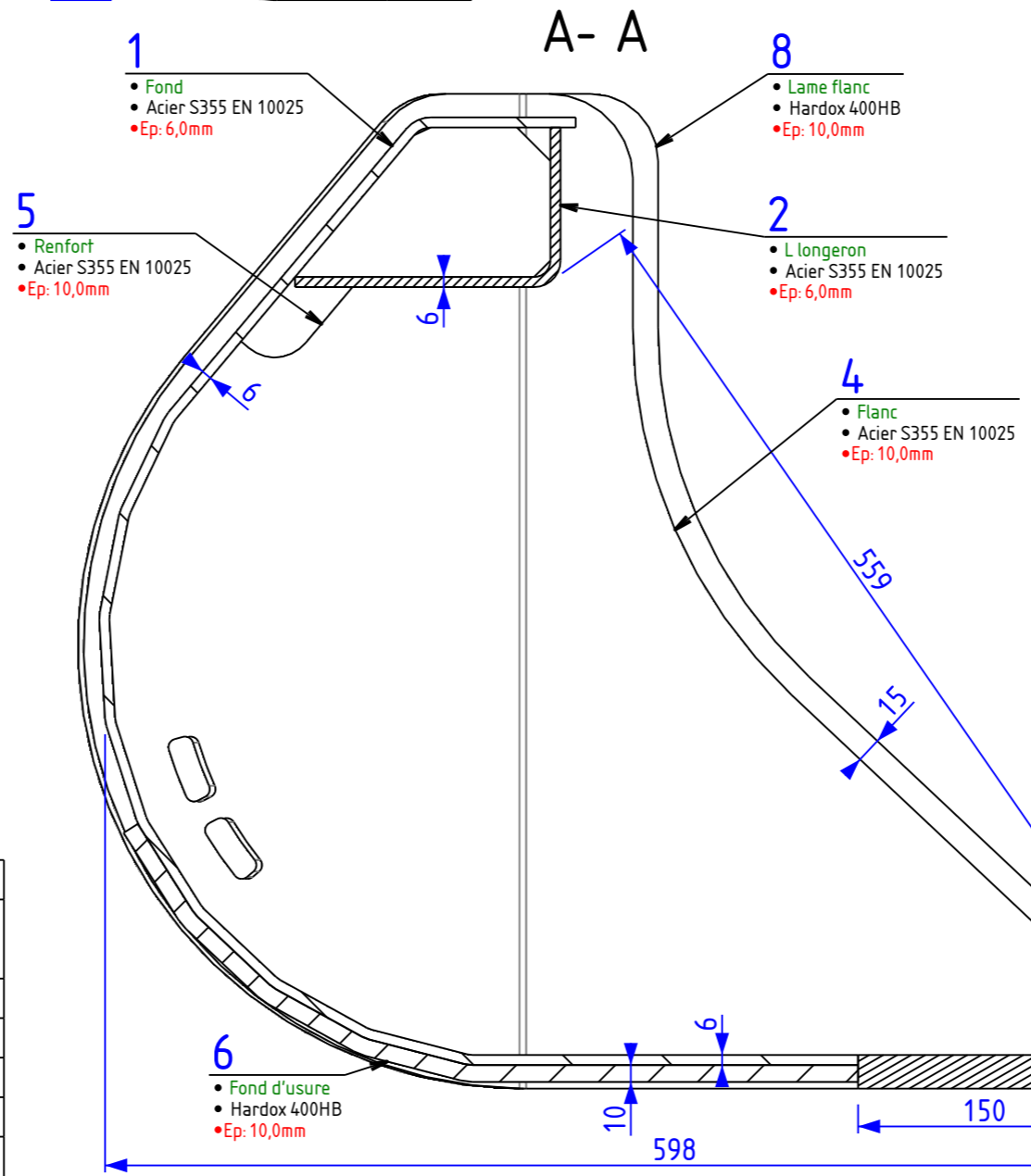

Repère de production	QTE	DESIGNATION	MATIERE	Epaisseur	MASSE
3	1	Flanc	Acier S355 EN 10025	10,00mm	16,74kg
4				10,00mm	
1		Fond	Acier S355 EN 10025	6,00mm	53,27kg
6		Fond d'usure	Hardox 400HB	10,00mm	41,21kg
2		L longeron	Acier S355 EN 10025	6,00mm	12,80kg
9		Lame d'usure	Hardox 400HB	20,00mm	27,57kg
7		Lame flanc		10,00mm	7,78kg
8		Lame flanc	10,00mm		
5		4	Renfort	Acier S355 EN 10025	10,00mm

Quantité: 1

Qté	1	Matière	-	Rev.	-	Masse U	187,56kg	Surface U	5,79m2
Designation		Bac curage 1,2m incl				Zone	-	Revision	
Rep. prod.		Référence -				Date révision	15-04-24	Revision	
Affaire		-				Date création	15-04-24	Ech.	2 : 25
Numéro d'affaire		-				Auteur	Admin	Folio	1/1
Format		-				-		A3	

BE-SBTP-Bacs

