

Repère de production	QTE	DESIGNATION	MATIERE	MASSE	EP	PLIS	LARGEUR	LONGUEUR	NBR OUVERTURES	PERIMETRE	SURFACE
	1			2,53kg			166,8	488,2		1211,0	
	2			5,22kg			172,6	500,7		1247,4	
	1			2,92kg			196,9	546,8		1389,5	0,0
				6,98kg			230,9	623,3		1603,6	
				8,33kg			263,1	710,8		1821,7	
				9,58kg			280,5	797,4		2026,4	
				10,68kg			298,5	876,6		2210,0	
		Lame	Acier	11,63kg	10,00	0	311,5	945,9	0	2371,3	
				12,42kg			320,9	1018,8		2511,9	0,1
				13,08kg			327,6	1081,8		2632,4	
				13,61kg			332,5	1132,8		2732,5	
				14,02kg			336,0	1172,8		2812,4	
				14,34kg			338,4	1202,8		2872,8	
				14,55kg			340,1	1223,6		2914,9	
				14,68kg			341,0	1235,8		2939,7	
	1	Pièce		7,36kg			341,3	1239,8		2947,9	
				29,15kg			700,0	700,0	60	6575,3	0,4

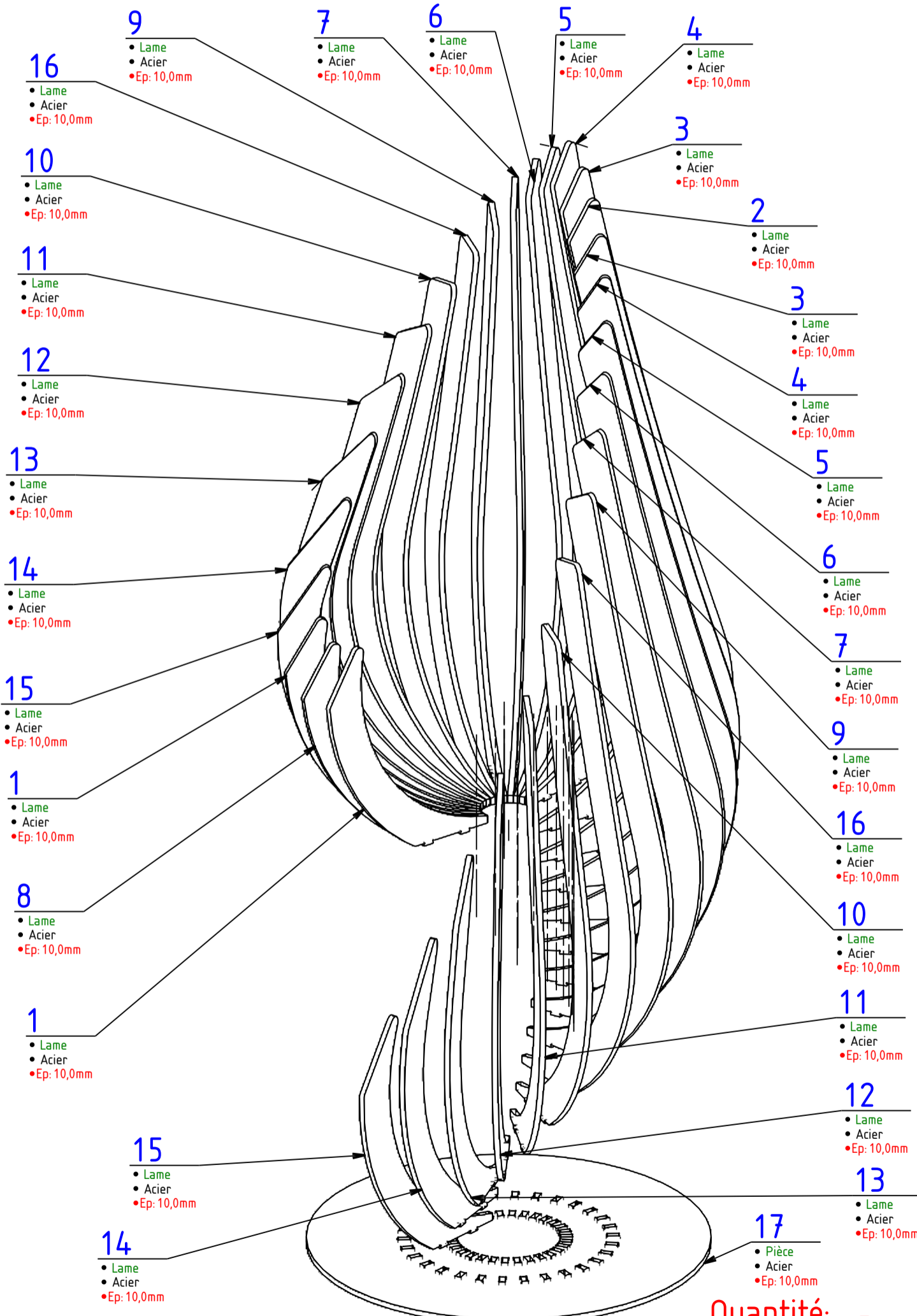

Quantité: -

Qté	Matière	Rev.	Masse U	Surface U
-	-	-	-	-
Designation Rep. prod. Affaire Numéro d'affaire			Zone Date révision Date création Auteur	
Référence - - -			Revision A 0 Ech. 3:25 Format A3 Folio 1/2	

BE-FirePit

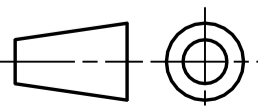

+32 474 369 305 Bstructe@outlook.com

D

C

B

A

8

8

7

7

6

6

5

5

4

4

3

3

2

2

1

1

A - A

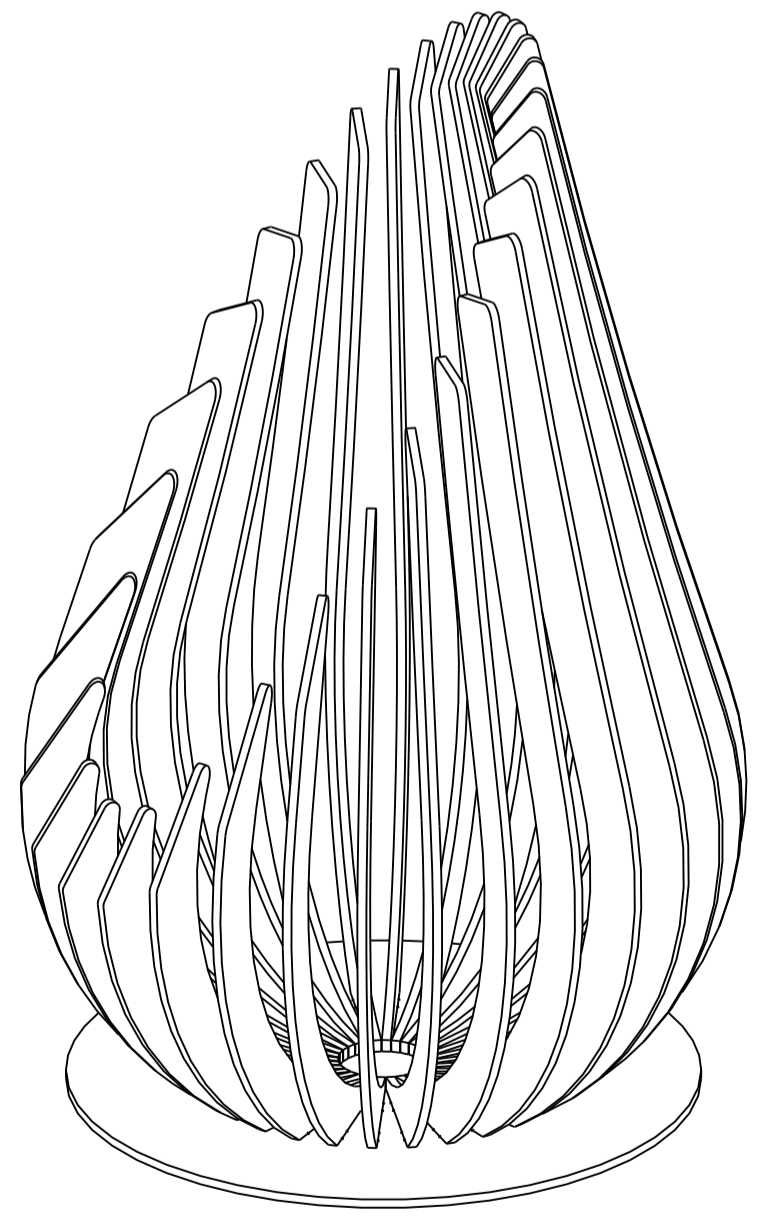
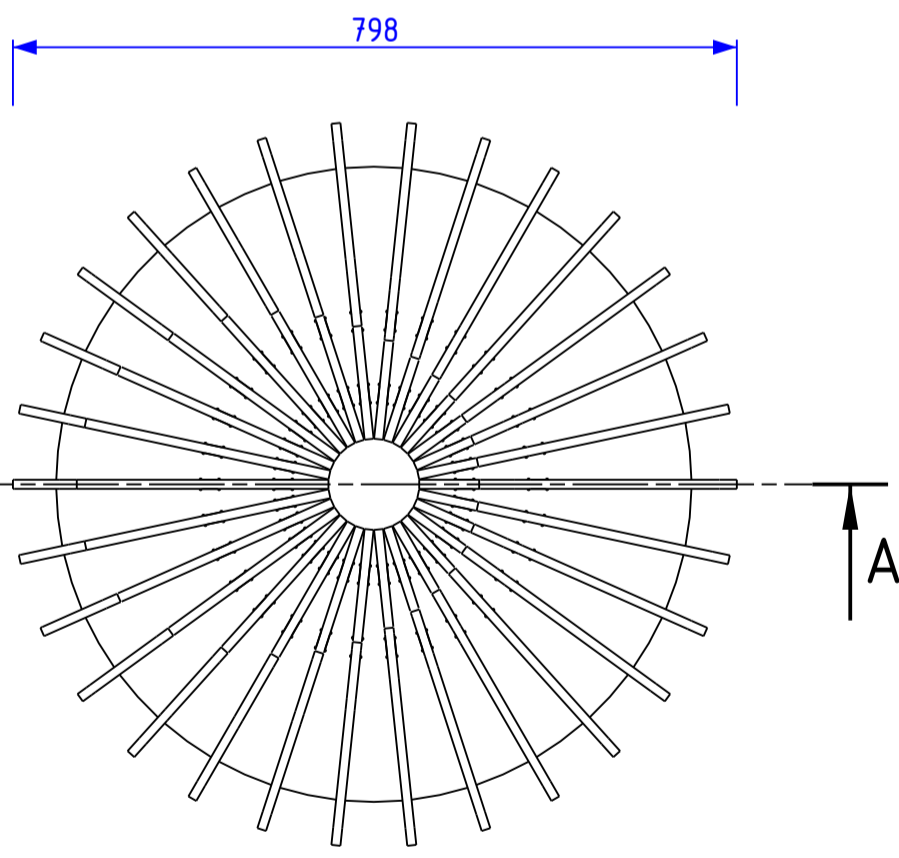
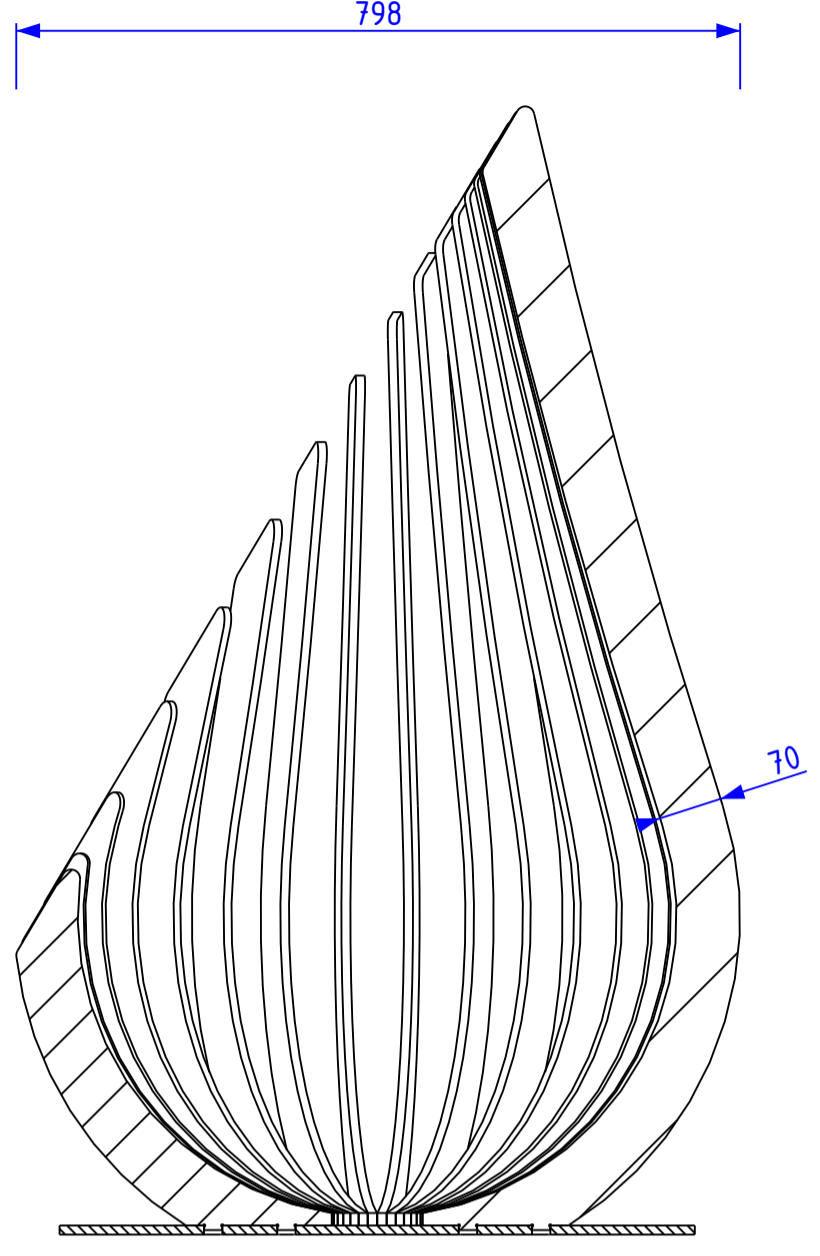
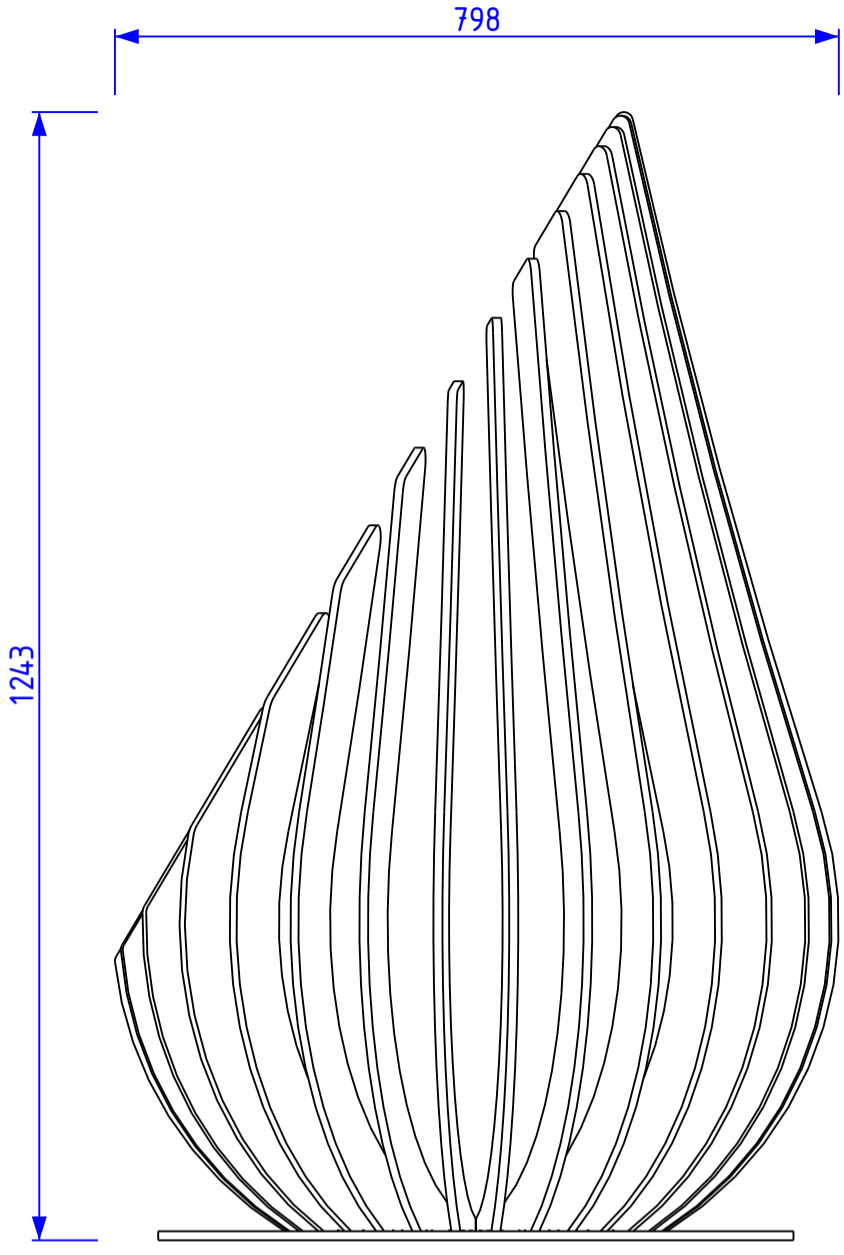

Quantité: -

BE-FirePit

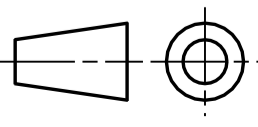

Qté	Matière	Rev.	Masse U	Surface U
-	-	-	-	-
		Designation	-	
		Rep. prod.	-	Référence
+32 474 369 305 ✉ Bstructe@outlook.com		Affaire	-	
		Numéro d'affaire	-	
		Date révision	04-05-24	Revision A 0
		Date création	04-05-24	Ech. 3 : 25 Format A3
		Auteur	Admin	Folio 2/2

D

C

B

A