

A

B

C

D

A

B

C

D

QTE	Assemblage(s) Parent(s)	Description assemblage(s)
-----	-------------------------	---------------------------

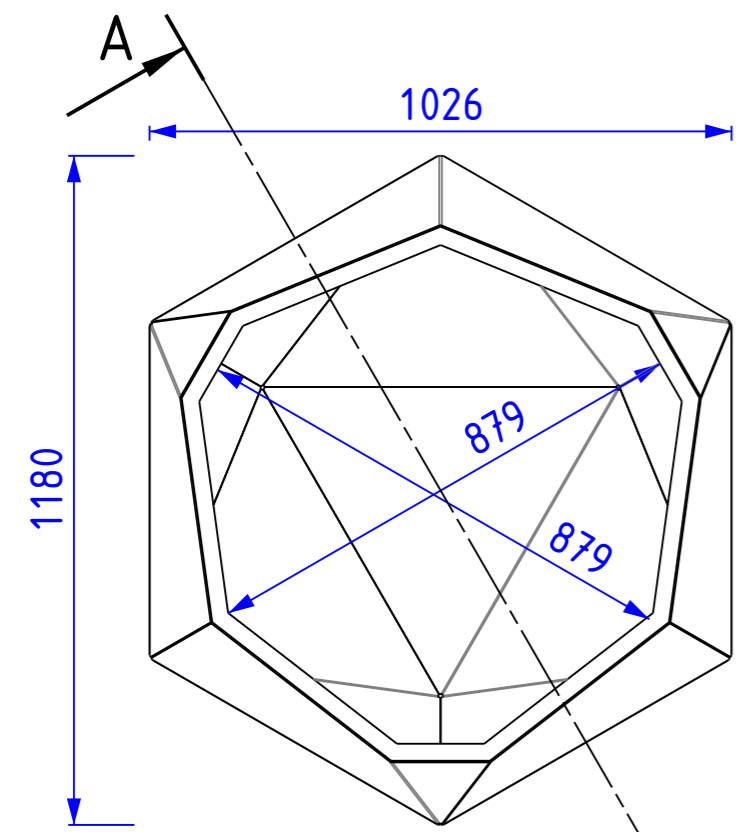
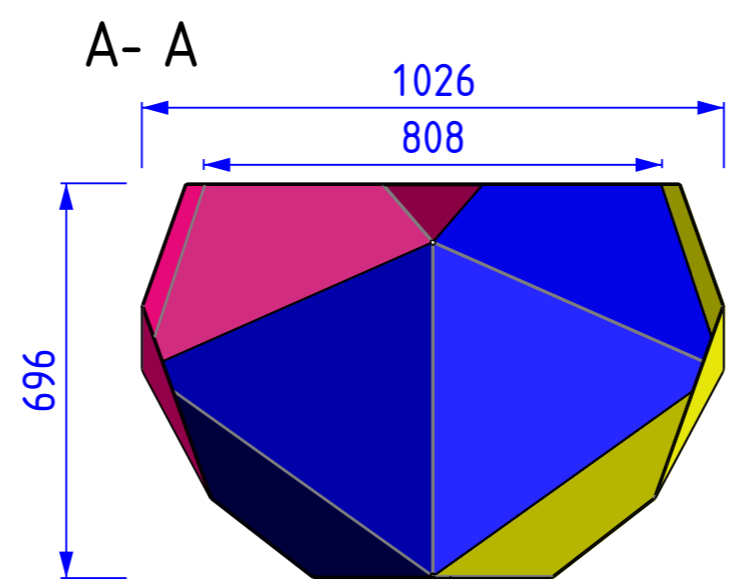
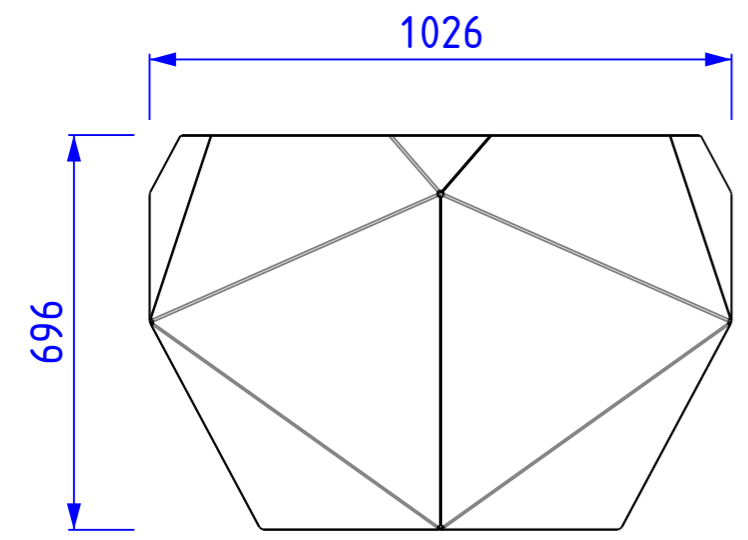

BE-BSS-SPT1200-001  
 • Flanc  
 • Acier  
 • Ep: 3,0mm

BE-BSS-SP1200-006  
 • Cerclage  
 • Acier  
 • Ep: 3,0mm

BE-BSS-SPT1200-005  
 • Flanc  
 • Acier  
 • Ep: 3,0mm

BE-BSS-SPT1200-002  
 • Flanc  
 • Acier  
 • Ep: 3,0mm

BE-BSS-SPT1200-004  
 • Flanc  
 • Acier  
 • Ep: 3,0mm

QTE	Référence	DESIGNATION	MATIERE	Epaisseur	MASSE
1	BE-BSS-SP1200-006	Cerclage	Acier	3,00mm	1,99kg
	BE-BSS-SPT1200-001	Flanc		3,00mm	9,89kg
	BE-BSS-SPT1200-002			3,00mm	7,13kg
	BE-BSS-SPT1200-003			3,00mm	11,20kg
	BE-BSS-SPT1200-004			3,00mm	14,96kg
	BE-BSS-SPT1200-005			3,00mm	

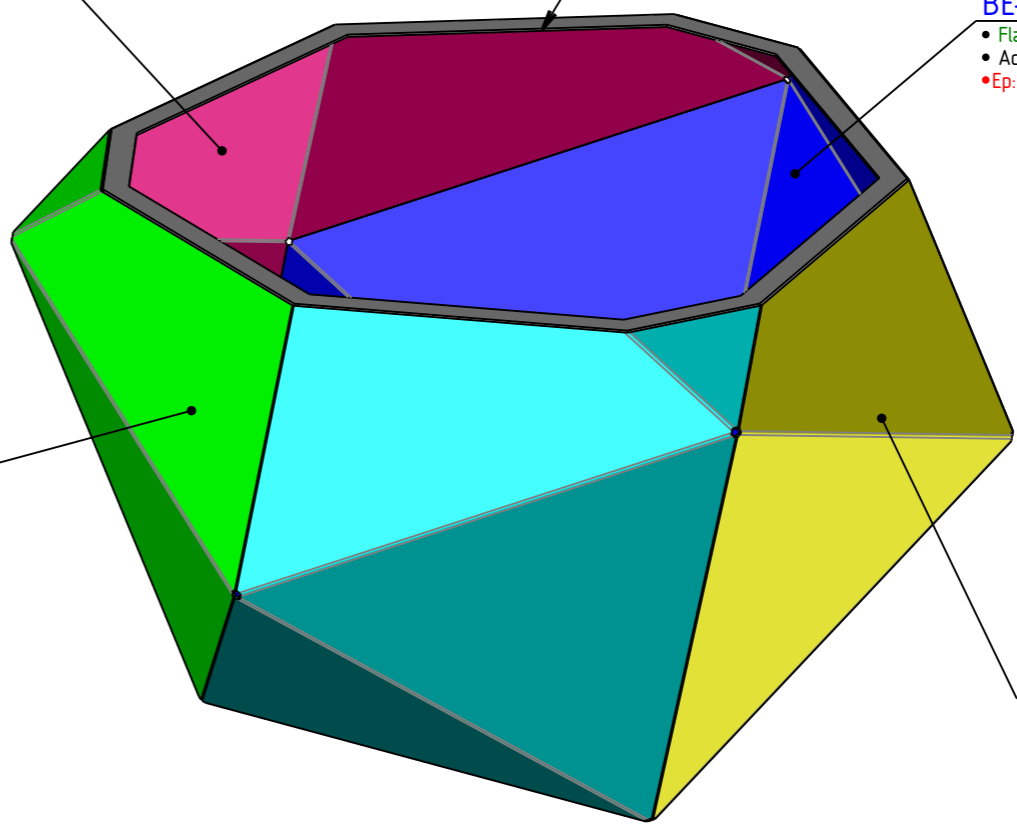

Quantité: 1

**BE-BSS**

Qté	1	Matière	-	Rev.	-	Masse U	60,14kg	Surface U	5,17m2	
		Designation	Pot1200		Zone	-				
+32 474 369 305    Bstructe@outlook.com		Rep. prod.	-	Référence	BE-BSS-SPT1200	Date révision	11-11-24	Revision	A 0	
		Affaire	-		Date création	11-11-24	Ech.	3 : 40	Format	A3
		Numéro d'affaire	-		Auteur	Admin	Folio	1/1	-	